

Yarn Preparation For Weaving And Knitting

Yarn preparation involves those processes that improve the yarn's weaveability or knittability.

Preparation Requirements for Weaving Yarns Warp Yarns

- Yarns must be aligned properly
- Yarn strength must be increased
- Yarn hairiness must be decreased
- Yarn smoothness must be increased
- Yarn elongation and flexibility must be sustained

Filling Yarns

Yarn must be wound properly and on a suitable package for high speed unwinding

Preparation Requirements for Knitting Yarns Weft Knitting

Yarn friction must be decreased Fiber shedding must be decreased Yarn smoothness must be increased

Warp Knitting

- Yarn friction must be decreased
 - Fiber shedding must be decreased
 - Yarn smoothness must be increased
 - Yarns must be properly aligned for introduction to knitting needles
- Yarn Preparation For Weaving And Knitting

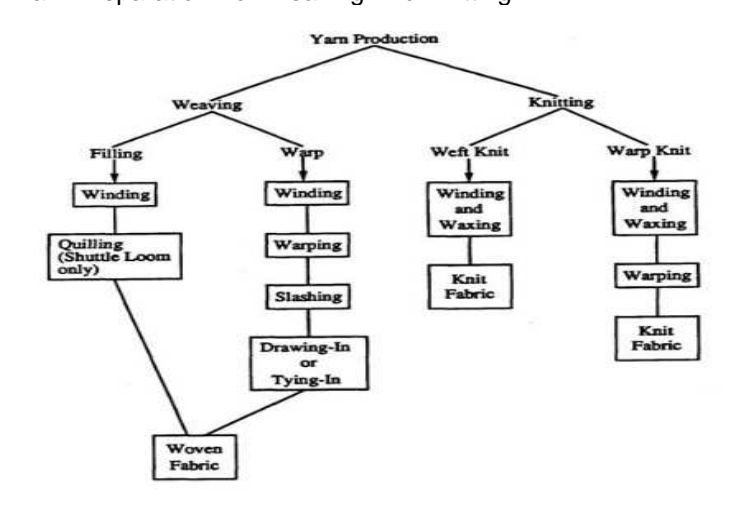

Winding

Materials Processed

Input - Yarn (spinning bobbins)

Output - Yarn (large cones, tubes, etc.)

Objectives of the Process

- Inspect the yarn
- Clearing of defects
- Lubricate the yarn
- Package the yarn

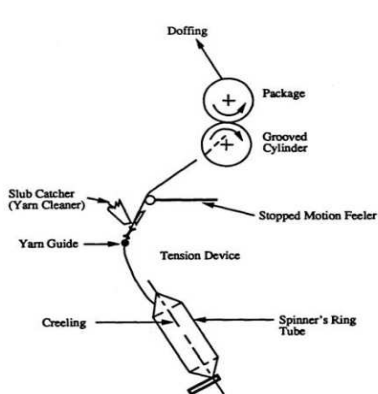

Elements of Winding

- Yarn withdrawal
- Yarn tensioning
- Yarn clearing
- Stop motion
- Take up

Figure 8-1 Open Wind Coner

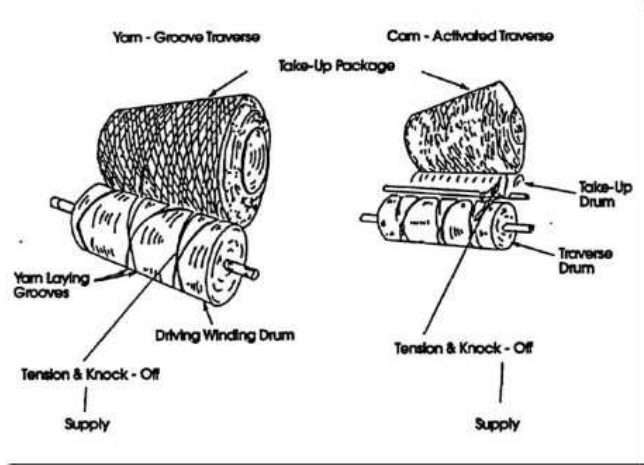

Yarn Preparation for Weaving

L Warping

A. An operation where yarn is transferred from single packages of yarn to an even sheet of yarn representing hundreds of ends and then wound onto a warp beam.

H. Producing An Even And Uniform Sheet Of Warp Yarn

A. The packages in the warper creel must be uniform in density, size, and wind configuration.

B. Tension applied in warping must be uniform throughout.

• C. Contact surfaces which the yarn passes must be smooth and must not impede the progress of the yarn.

D. The speed of the warper must not exceed that at which the yarn can be withdrawn from supply packages without undue strain.

E. Warp winding speed must be controlled and maintained at a constant rate throughout.

III. Direct Versus Indirect Warping

A. Direct Warping

1. Warp is wound directly onto section beams.

2. Used predominantly in preparing yarn for warp knitting and weaving.

B. Indirect Warping

1. Warp is wound in bands onto pattern drum and then transferred onto a beam in a separate operation.

2. Used for fancy pattern warps or where creel capacity is limited.

Figure 8-2 Single End Creels

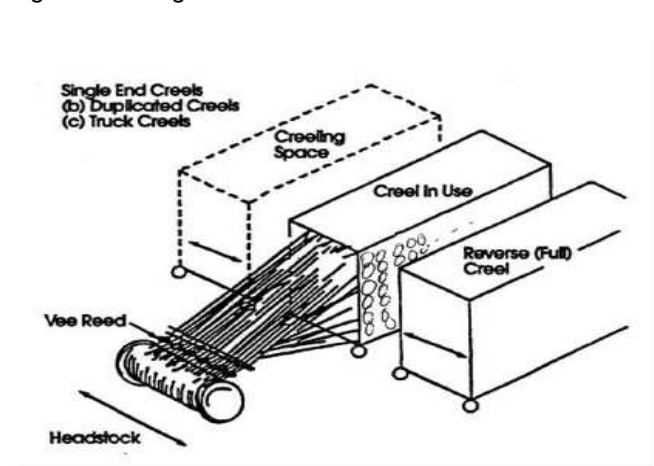

Figure 8-3 Traveling Package Creel

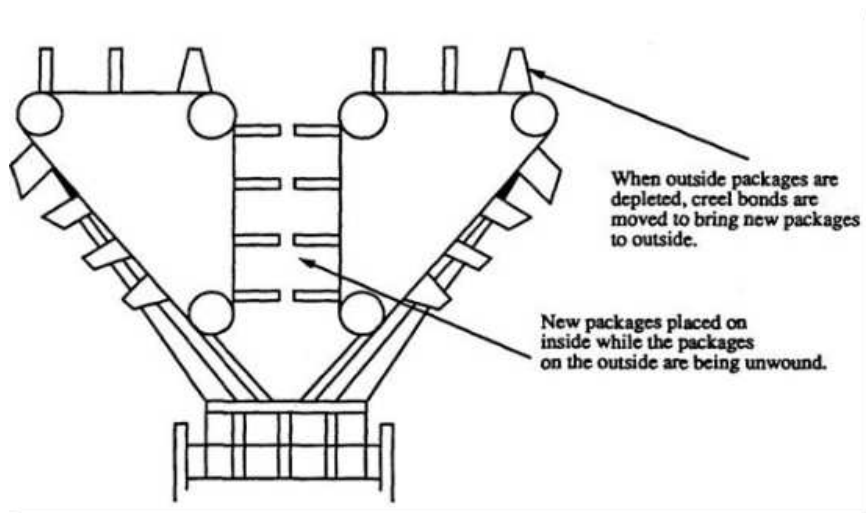
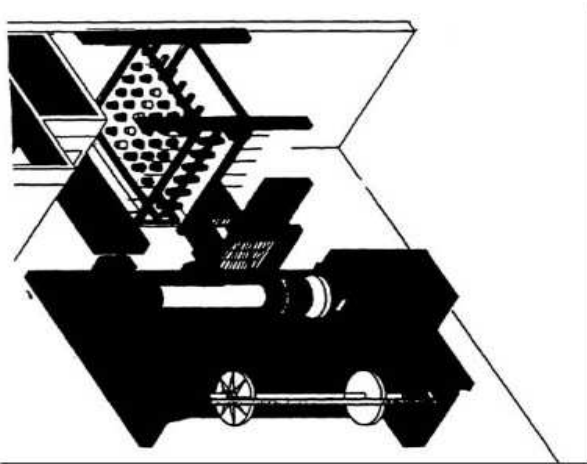

Figure 8-4 Indirect Warping: Drum Warper



Slashing

L Objectives

- A. Strengthen the yarn
 - B. Make outer surface of yarn smoother
 - C. Lubricate the yarn
 - D. Have no effect on subsequent processes or resulting fabric
- #### IL Why Warp Yarns Need To Be Strengthened
- A. To overcome tension levels in the warp
 - 1. Constant average tension determined by:
 - a. rate of take-up of cloth and let-off of warp
 - b. contraction of warp due to crimp
 - c. stretch of warp due to tension
 - 2. Cycling variations in tension
 - a. due to shedding
 - b. due to beat-up
 - c. higher level in dense fabric
 - d. highest tension in cycle is where a weak yarn will break

3. Random variations in tension
 - a. due to large, badly shaped knot
 - b. yarn and fiber entanglements
 - c. knot tails entangling
 - B. To overcome weaknesses in the yarn created by:
 1. Yarn damage caused by the machine
 2. Weak places in the yarn supplied
 3. Inadequate distribution of load over all warp ends
 4. Inadequate knotting or joining
 - III. Sections Of The Slasher
 - A. Beam creel
 - B. Size box
 - C. Drying unit
 - D. Warp separation
 - E. Headstock
 - IV. Size Add-On
 - V. Factors Affecting Size Add-On
 - A. Yarn characteristics
 - B. Number of ends and tension of warp
 - C. Squeeze roll control and conditions
 - D. Residence time of yarn in size box
 - E. Viscosity of mix
 - VI. Important Ingredients In A Size Mix
 - A. Adhesives
 - B. Lubricants
 - C. Additives
 - D. Water or solvent
 - VII. Parameters Controlled In The Size Box
 - A. Level of size solution
 - B. Temperature
 - C. Concentration of size liquor
 - D. Squeeze roller pressure
 - E. Yarn speed
 - VIII. New Sizing Techniques
 - A. High pressure squeezing
 - B. Hot melt sizing
 - C. Foam sizing
 - IX. Slashing Calculations
- Figure 8-5 Slashing - Preparatory To Weaving

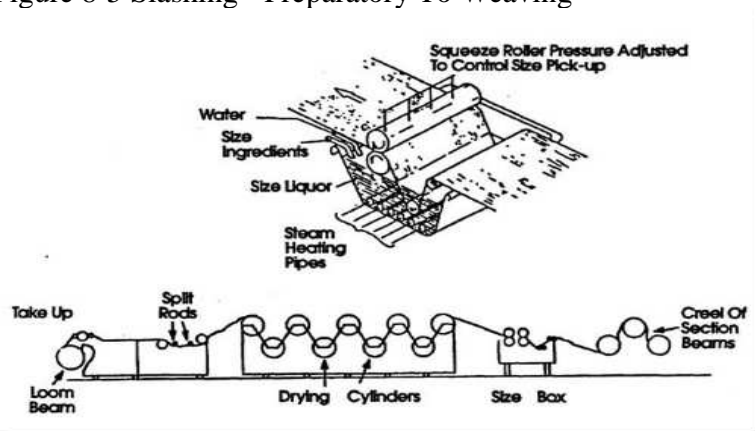

Requirements For A Quality Warp Beam

Objective: To Make A 'More Perfect Warp Beam'

- Ends wound straight and parallel to one another from beginning of beam to the end with each end holding its relative position in the warp with no "Rolled", "Crossed", "Stuck", or "Lost Ends".
- Tension uniform on all ends.
- Density of the warp is uniform from beginning of beam until full beam.
- Selvage ends flat with the rest of the warp.
- Size added is uniformly applied on all ends and improves warp weaveability.

Warp Preparation

Drawing-In

Provides each warp yarn with its drop wire, heddle, and reed dent. Tying-In

When mass producing the same fabric by simply tying each end of a new beam to its corresponding end of the old beam

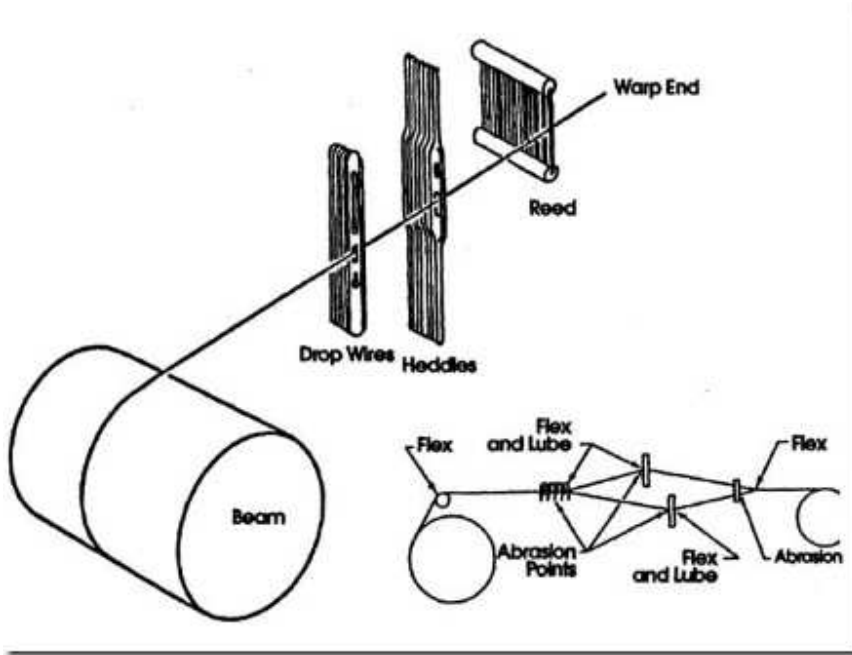

Side View Of A Loom

This sketch shows why the yarn must be flexible and lubricated to withstand the weaving operation. The warp sizing material must impart flexibility, elasticity, lubricity and abrasion resistance to the yarn.